

THE FINE PRINT TELLS ALL WITH AUTOMATIC TRANSFER SWITCHES

By Stan Pukash

On-site standby power solutions for residences are relatively new for most people, as are the transfer switches that provide the critical link between the utility and backup power sources. However, the residential market for these products is growing rapidly, as the possibility of more frequent, relatively long-term power outages becomes a more real concern. More generator sets and their accompanying transfer switches are finding their way onto the shelves of megastores—and into the minds of contractors, and ultimately municipal electrical inspectors throughout the United States.

Unfortunately, a considerable number of products that are being called transfer switches have never been tested to the stringent criteria contained in UL Standard 1008—the only UL standard dedicated exclusively to transfer switches. The problem is compounded by the fact that these same switches probably display a UL label prominently on their packaging and on the switch enclosure. While this may imply compliance with an applicable UL standard, this is often not the case. This leaves contractors and electrical inspectors in the compromised position of approving the installation of a transfer switch that appears acceptable when in fact it may not be. It could also be argued that installation of transfer switches that have not complied with UL1008 is a violation of the National Electrical Code that requires that products be tested and listed only for their intended use.

Unless a transfer switch is evaluated and complies with the criteria in UL1008, it can be wholly unfit for service. When pressed into the service it was ostensibly intended to perform, these switches can destroy the generator to which they are connected, cause a fire, or both. The potential liability issues arising from this situation are enough to raise goose bumps on the arms of inspectors and contractors everywhere.

The author is director, strategic business development at ASCO, Florham Park, N.J.

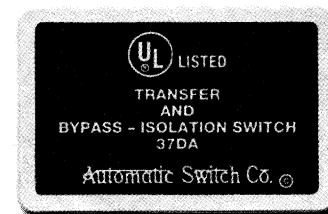

Before purchasing or installing an automatic transfer switch for these applications, make sure it has a UL label that says "Automatic Transfer Switch," "Transfer and Bypass Isolation Switch," or "Non-Automatic Transfer Switch." The bottom label shown here does not have the proper designation.

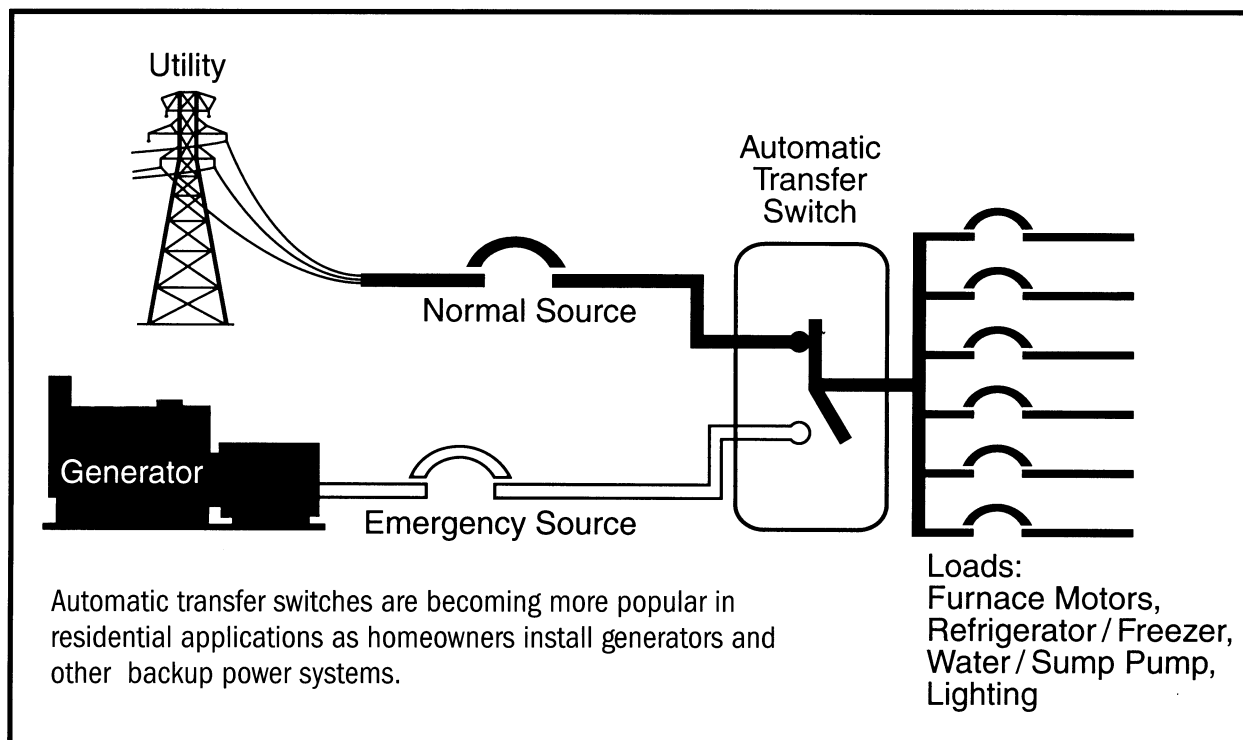

WHAT'S THE DIFFERENCE?

Transfer switches are deceptively simple devices that carry an enormous burden when called upon in an emergency. That is, they must bring two electrical feeders (utility and standby system) together in the same enclosure, connecting only one to the load. It's obviously imperative that the switch interrupt service from the utility connection before connecting the generator set, and vice versa. It's the responsibility of the switch to ensure that the arc created when power is interrupted from one source is extinguished before the second source is connected. If this doesn't happen, the generator will more than likely be destroyed, and in extreme cases, a fire or personal injury can occur. In addition, if the sources are not kept separate at all times, the utility line can become energized by the residential generator, endangering utility workers.

The peculiarities of transfer switches are significant enough that in the late 1960s, the electrical industry and Underwriters Laboratories collaborated to create a standard by which all transfer switches should be judged—UL1008, which was adopted in 1970. This standard delineates a list of performance criteria that these devices must be able to meet or exceed before being considered safe. It's not a simple standard, and its tenets are stringent.

A transfer switch compliant with UL1008 requires the use of proven, quality components, and the compliance process is lengthy. Ignoring either one saves money and improves the manufacturer's time-to-market, but results in a product with dubious claims to performance and safety. However, this has not precluded manufacturers from placing the UL-listed label on their transfer switches, even though they have not met the only applicable UL standard, UL1008.

It's easy to see why this is so. UL1008 specifies rigorous construction and performance standards, manufacturing and production tests, ratings, markings and installation test procedures. Construction guidelines alone cover corrosion, terminals, mounting, internal wiring, the operating mechanism and many other transfer switch parameters, including the distance that must be maintained between live switch components and preferred construction materials.

The performance section of UL1008 covers operation under normal, over-voltage and over-temperature conditions, among others. The switch must be able to survive an endurance test of up to 6,000 operations and withstand very high levels of short-circuit current without being destroyed, shorting between the two sources, or causing a fire, while allowing the main circuit breaker to clear the fault. For example, a switch rated 100A must be able to withstand a short-circuit current of 5,000A until the fault is cleared. Components and design techniques required to produce transfer switches that can stand up to this kind of testing are costly, as is the testing process itself.

WHAT TO DO

While a transfer switch that has not been tested under the conditions specified in UL1008 and been found acceptable may perform adequately, there is as great a likelihood that it may not. The final determination will invariably be made when the switch is called upon to perform its intended function, which is equivalent to testing a new fire hose during its first four-alarm fire.

Consequently, any contractor installing such a transfer switch should at least be aware that he or she is using a device that has not been proven safe as defined by UL1008

for transfer switches, and electrical inspectors should be knowledgeable about whether or not a particular transfer switch meets UL1008 requirements. Unfortunately, neither of these tasks is as easy as it could be.

Simply locating a UL label on the switch gives no accurate indication that the product complies with UL1008. This is because the product might display a UL label even if it has not complied with UL1008, but rather has complied with other, far-less-rigorous UL standards (e.g., one that applies to lighting contactors) that do not expressly address the unique characteristics of transfer switches.

Only a UL label that specifically states “Automatic Transfer Switch,” “Transfer and Bypass-Isolation Switch,” or “Non-Automatic Transfer Switch” is positive proof of compliance with UL1008. The labeling requirements for transfer switches are outlined in UL’s “Electrical Construction Equipment Directory,” also known as the

“Green Book,” in UL categories WPVQ, WPWR, WPXT and WPYV.

As standby-power systems become more prevalent in private residences, contractors and electrical inspectors will encounter more transfer switches from more manufacturers. The potential liabilities inherent in installing transfer switches not tested to UL1008 make it imperative that contractors become knowledgeable about which products are and are not compliant. The same liability issues apply to electrical inspectors, who must go a step beyond simply looking for just any UL label on the equipment in order to ensure that it’s safe.

A tangible difference exists between compliant and non-compliant transfer switches. This fact may only become evident once the device has safely performed, or failed in performance of its intended function, or worse has caused bodily harm. Unfortunately, at this point, it is far too late.

***The number one name in Automatic
Transfer Switches for over 110 Years.***

ASCO, founded in 1888, is the world's leader in the control of electric power, and is headquartered in Florham Park, NJ, USA.

ASCO power transfer switches safeguard homes and small businesses, data and telecommunications networks, industrial processes, and critical installations from health care facilities to financial transaction centers...around the globe.



We keep your power on

Asco Power Technologies, L.P.
Hanover Road • Florham Park • New Jersey • 07932 • USA
800-937-ASCO • www.asco.com